

VNV-1 80 KP



Centrifugal fan in fireproof casing with air capacity up to 150 m³/h

Application

- Exhaust ventilation of high-rise residential and non-residential premises with increased fire prevention requirements.
- Suitable for premises with mono-pipe ventilation system.
- Mounting in kitchens, bathrooms, toilets, storerooms and other household areas.

Design

- Supplied in fireproof casing KP 80 for flush mounting to wall (for detailed description and casing mounting procedure refer page 12).
- Equipped with a maintenance-free fire-retarding damper. As the temperature in the shaft reaches 90°C the thermal fuse melts and the damper shuts automatically hot air access off, so the flame and smoke penetration through the ventilation shaft system is prevented.
- The fire-retarding damper serves as a backdraft damper when the fan is off and prevents air moving from the ventilation shaft.
- The front panel is made of high-quality durable ABS plastic.
- The turnable front panel conceals possible inaccuracies of the fan casing installation.

Motor

- Energy efficient 2- or 3-speed motor on ball bearings with minimum energy demand.
- Automatic maintaining of constant pressure and air flow in the duct.
- Fastened to the casing by means of latches with no tools.
- For precise characteristics, low noise level and safe operation each turbine is dynamically balanced while assembly.

Modifications and options

- VNV-1 80 KP T** – fan with timer.
- VNV-1 80 KP TR** – fan with regulated timer.
- VNV-1 80 KP I** – fan with interval switch.
- VNV-1 80 KP F** – fan with photosensor.
- VNV-1 80 KP H** – fan with humidity sensor.
- VNV-2 80** – fan with front panel from ground aluminium.
- VNV-2 80 Chrome** – fan with front panel from mirror finish aluminium.
- VNV-2 80 Gold** – fan with front panel from golden mirror finish aluminium.
- In case of second room ventilation system the casing is equipped with extra branch pipes with three air duct layout modifications for adjacent room ventilation. In such a case the kit for exhaust ventilation of the adjacent room is used.
- VNV-1 80 KP-R** – fan with extra branch pipe on the right.
- VNV-1 80 KP-L** – fan with extra branch pipe on the left.
- VNV-1 80 KP-D** – fan with extra branch pipe on the bottom.

Control

- Speed switch is performed with the external manual speed switch. P3-1-300 switch for the three speed fan models and P2-1-300 for the two speed fan models. The speed switches are not included into the delivery set and are available upon order.

Options for 2 speed fan models



T – timer modification:

The fan is switched on to the maximum speed manually with the external switch, turn-on delay time is 50 seconds. The return to default position is performed with the timer, run-out time is 6 minutes. Continuous low speed operation is possible.



TR – adjustable timer modification:

The fan can be switched to the maximum speed manually with the external switch. Turn-on delay time is set with the internal regulator ranging from 0 to 150 seconds. Run-out time is set with the internal regulator from 2 to 30 minutes. Continuous low speed operation is possible.



I – interval switch modification:

The fan switches periodically to the maximum speed while operation. The switching interval is set by means of the internal regulator ranging between 0.5 and 15 hours. Run-out time is 10 minutes. The fan can be switched manually with the external switch, turn-on delay time is 50 seconds. Continuous low speed operation is possible.



F – built-in photosensor modification:

The fan switches to the maximum speed after turning-on the light in the room, turn-on delay time is 50 seconds. After decrease of illumination level below the set threshold the fan switches to the run-out operation mode with the duration from 2 to 30 minutes set by the internal regulator. Continuous low speed operation is possible.



H – humidity sensor modification:

The fan switches to the maximum speed as relative humidity level in the room increases. It switches off as relative humidity level drops by 10 % below the set level. The humidity threshold is adjusted in the range between 60 % and 90 %. Force switching to the maximum speed is provided, in this case the turn-on delay time is 50 seconds, and the run-out time is set by the internal regulator between 2 and 30 minutes. Continuous low speed operation is possible.

Order code

VNV-	front panel	air flow [m ³ /h]	80 KP	extra branch pipe	extra modifications*	front panel colour
	1 - plastic	- 60/100/150		- no extra	T	- white
	2 - aluminium	A - 35/60		branch pipe	TR	Chrome
		B - 35/100		-L - on the left	I	Gold
		C - 35/60/100		-R - on the right	F	
		D - 60/100		-D - on the bottom	H	

* for 2 speed fan models only

Accessories

Filter Speed switch Bracket Thermovent Clamps



Accessories description and list see on p. 24

Aerodynamic characteristics

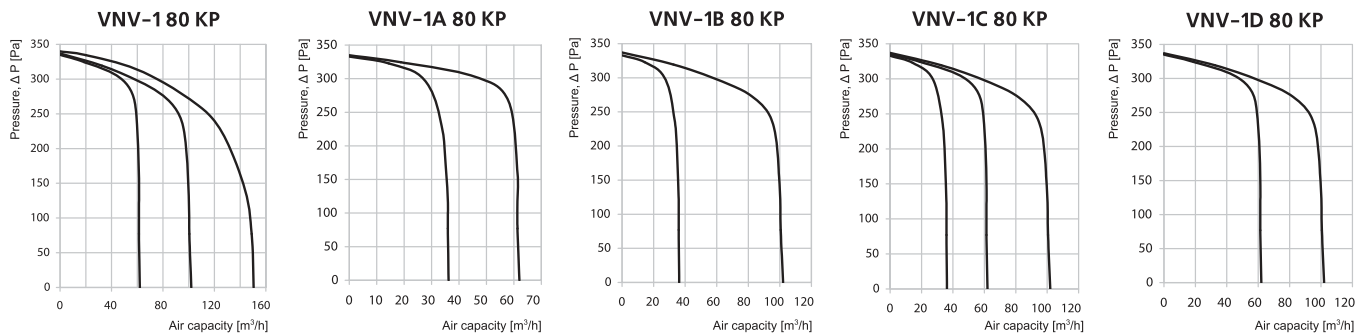

The abrupt curves show high pressure performance of VNV fans and constant air flow while operation of many fans integrated into single ventilation shaft:

- available pressure up to 270 Pa at 35 m³/h;
- available pressure up to 260 Pa at 60 m³/h;
- available pressure up to 220 Pa at 100 m³/h.

Technical characteristics

Model	VNV-180 KP	VNV-1A 80 KP	VNV-1B 80 KP	VNV-1C 80 KP	VNV-1D 80 KP
Number of speeds	3	2	2	3	2
Voltage 50 Hz [V]	220-240	220-240	220-240	220-240	220-240
Power consumption [W]	17/27/48	12/17	12/27	12/17/27	17/27
Current [A]	0,14/0,18/0,21	0,12/0,14	0,12/0,18	0,12/0,14/0,18	0,14/0,18
Connection to power supply network [mm ²]	4x1,5	3x1,5	3x1,5	4x1,5	3x1,5
Maximum air flow [m ³ /h]	63/102/150	35/63	35/102	35/63/102	63/102
Rotation speed [min ⁻¹]	1350/1830/2640	890/1350	890/1830	890/1350/1830	1350/1830
Sound pressure level at 3 m distance [dBA]	30/35,2/43,7	26,6/30	26,6/35,2	26,6/30/35,2	30/35,2
Maximum operating temperature [°C]	50	50	50	50	50

Front panel modifications



Overall dimensions

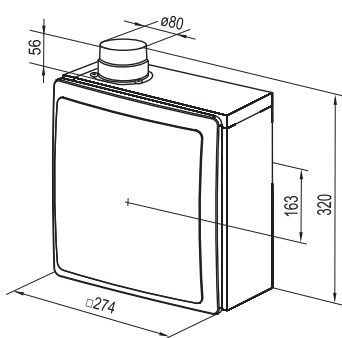

Mounting example



The fan casing is mounted during construction works and connected to the main ventilation shaft. Electric wiring for connection of the VNV-180 ventilation unit is led out through a special hole in the casing. The front panel is covered with the protective cardboard plate supplied with the unit to avoid damages or contamination during finishing works in the room. After finishing the works the protective cardboard plate is removed and the VNV-180 ventilation unit is installed into the casing that is connected to the wiring.

Certificates



The fans meet safety norms and standards and electromagnetic compatibility directives.